

HYPONTECH

ENERGIZING FUTURE

USER MANUAL V1.00

HBP-H3 / H6 / H9 / H12 / H15

HBP HV Battery Series



CONTENT

1. INTRODUCTION	3
1.1 Safety And Warnings	3
1.2 Label Description	4
1.3 Emergency Measures	5
2. Product Specification	6
2.1 System Performance Parameter	6
2.2 Battery Module	7
2.3 Appearance	8
3. Storage and Installation	10
3.1 Storage	10
3.2 Installation Environmental Requirement	10
3.3 Installation clearance requirements	11
3.4 Installation location precautions	12
3.5 Installation Angle Requirements	13
3.6 Safety Gear	13
3.7 Unpacking inspection	13
3.8 Equipment installation	15
4. Maintenance	21
4.1 TroubleShooting	21
4.2 Replacement of main component	22
4.3 Battery Maintenance	23
5. Transportation	24
6. Disclaimer	25

1. INTRODUCTION

1.1 Safety And Warnings

1. High voltages in the battery could cause lethal electrical shocks. All persons who are responsible for mounting, installation, commissioning, maintenance, tests, and service of the battery products must be suitably trained and qualified for corresponding operations. They **MUST** be experienced and have knowledge of operation safety and professional methods. All installation personnel must have knowledge of all applicable safety information, standards, directives, and regulations.
2. Do not hit, pull, drag, squeeze or step on the equipment or put the battery into fire. Otherwise, the battery may explode.
3. Do not disassemble, modify, or replace any part of the battery or the power control unit without official authorization from the manufacturer. Otherwise, it will cause electrical shock or damages to the equipment, which shall not be borne by the manufacturer.
4. Do not place the battery in a high temperature environment. Make sure that there is no direct sunlight and no heat source near the battery. When the ambient temperature exceeds 60 °C, it will cause fire.
5. The battery should be tied or fixed during transportation. The battery should be protected from heavy vibrations and shocks during transportation. The transport of the battery requires two people for lifting, there is one handle on the left and one on the right.
6. Do not use the battery or the power control unit if it is defective, broken, or damaged. The damaged battery may leak electrolytes.
7. Contact after-sale service immediately if the battery is not able to be started. Otherwise, the battery might be damaged permanently.
8. Do not move the battery system if it is connected to external battery modules. Contact after-sales service if the battery shall be replaced or added.

1.2 Label Description

	DANGER, WARNING AND CAUTION
	HIGH VOLTAGE AVOID CONTACT
	USER MANUAL IN PACK
	BATTERIES CONTAIN FLAMMABLE MATERIALS, BEWARE OF FIRE
	DO NOT DISPOSE WITH HOUSEHOLD WASTE
	CE MARKS
	TUV MARKS
	RECYCLABLE AND REUSABLE

1.3 Emergency Measures

Battery Electrolyte Leakage

If the battery module leaks electrolyte, avoid contact with the leaking liquid or gas. The electrolyte is corrosive. It will cause skin irritation or chemical burns to the operator. Anyone contacting the leaked substance accidentally has to do the following:

- **Breath in the leaked substance:** Evacuate from the polluted area, and seek immediate medical assistance.
- **Eye contact:** Rinse your eyes for at least 15 minutes with clean water and seek immediate medical assistance.
- **Skin contact:** Thoroughly wash the touch area with soap and clean water, and seek immediate medical assistance.
- **Ingestion:** Induce vomiting, and seek immediate medical assistance.

Fire

- The battery may explode when the ambient temperature exceeds 150°C. Poisonous and hazard gas may be released if the battery is on fire.
- In the event of a fire, please make sure that the carbon dioxide extinguisher or Novac1230 or FM-200 is nearby.
- The fire cannot be put out by water or ABC dry powder extinguisher. Firefighters are required to wear full protective clothing and self-contained breathing apparatus.

2. Product Specification

2.1 System Performance Parameter

The battery system supports capacity expansion. A maximum of 5 battery modules can be used to extend the usable energy of the battery system. Strictly follow the expansion requirement. For details, please contact the Dealer or Manufacturer. Otherwise, under-voltage, overvoltage or voltage difference might occur to the battery system.

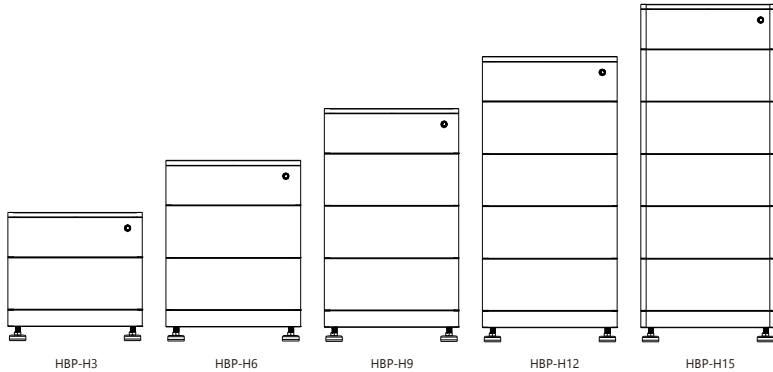

Table 2-1 The parameter of HBP system

HBP HV Battery Series					
Model	HBP-H3	HBP-H6	HBP-H9	HBP-H12	HBP-H15
Nominal Battery Energy /kWh	3.072	6.144	9.216	12.288	15.360
Nominal Capacity /Ah	30Ah	30Ah	30Ah	30Ah	30Ah
Nominal Voltage /Vdc	102.4	204.8	307.2	409.6	512
Dimension [W*D*H]/mm	500*350*413	500*350*602	500*350*791	500*350*980	500*350*1169
Net Weight /kg	44.6	73.6	102.6	131.6	160.6
Battery Module Quantity	1	2	3	4	5
Max. Charge &Discharge Current/A (Communication with the inverter)	22A/25A				
Charging Temp. Range/°C	0-+50				
Discharging Temp. Range/°C	-10-+50				
Communication	CAN				
Cycle Life	4000 Cycles@25°C,0.5C,90%DOD				
Protection Level	IP55				
Max. Operating Altitude/m	2000				
Certification	TUV/CE/IEC62619/IEC63056/ IEC62477/UN38.3				

2.2 Battery Module

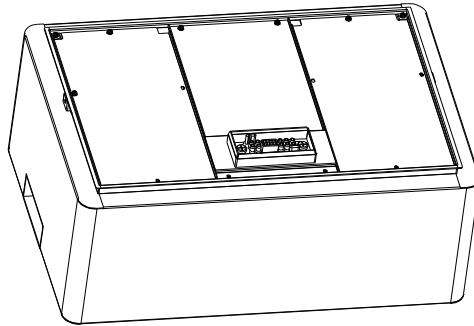
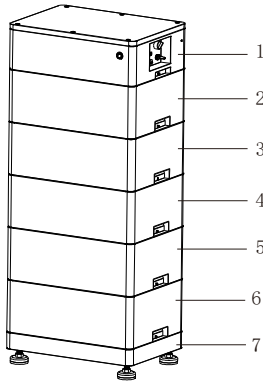

Table 2-2 Product parameters

Model Name	HP10230
Cell Technology	Li-ion(LFP)
Battery Module Rated Capacity (kWh)	3.072
Battery Module Rated Voltage (Vdc)	102.4
Battery Module Rated Capacity (Ah)	30
Battery Cell Rated Voltage (Vdc)	3.2
Battery Cell Rated Capacity (Ah)	30
Battery Module Cell Quantity in Series (pcs)	32
Battery Module Charge Voltage (Vdc)	116.8
Battery Module Charge Current (Standard) [A]	6
Battery Module Charge Current (Normal) [A]	15
Battery Module Charge Current (Max.) [A]	30
Battery Module Discharge lower-Voltage (Vdc)	89.6
Battery System Discharge Current (Standard) [A]	15
Battery Module Charge Current (Normal) [A]	15
Battery Module Charge Current (Max.) [A]	30
Dimension(W*D*H, mm)	500*350*224
Communication	CAN
Pollution Degree (PD)	II
Ambient Temperature(°C)	-10~50
IP Grade	IP55
Weight(kg)	29

2.3 Appearance

Battery System



No	Model Name
1	Battery Controller
2、3、4、5、6	Battery HP10230
7	Base

Battery Controller right view

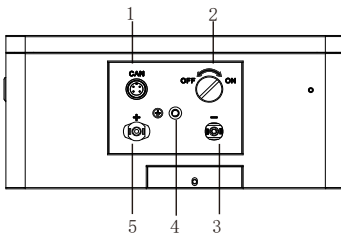

Battery Controller front view

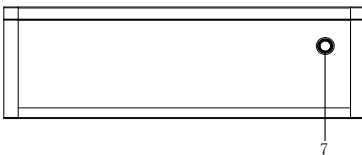

Battery Controller left view

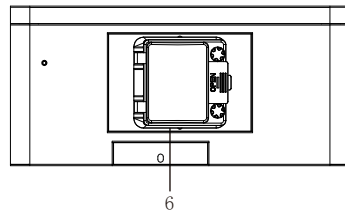

Battery Controller bottom view

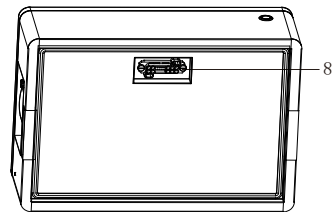

No	Model Name	No	Model Name
1	BMS: CAN Terminal	2	Power On Switch
3	External Negative	4	Grounding Point
5	External Positive	6	Circuit Breaker
7	Button Indicator	8	Connector Socket

HP10230 top view

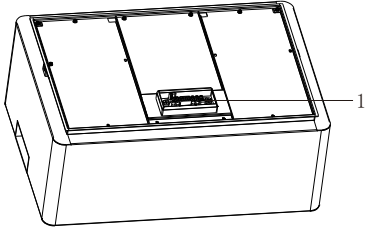

HP10230 bottom view

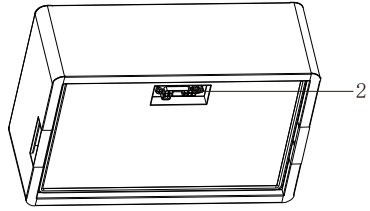

Base

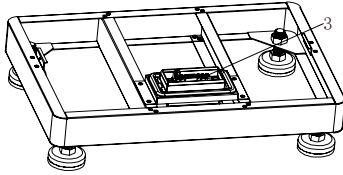

No	Model Name
1	Connector plug
2	Connector socket
3	Connector plug

3. Storage and Installation

3.1 Storage

If the equipment is not to be installed or used immediately, please ensure that the storage environment meets the following requirements:

1. Do not unpack the outer packing box or throw the desiccant away.
2. Complete the equipment installation in three days after unpacking it. Pack and store the equipment using the original packing box if it is not installed.
3. Stack the equipment complying with the labels and requirements on the packing box.
4. The equipment must be stacked with caution to prevent them from falling.
5. Keep the equipment away from flammable, explosive, and corrosive matters.
6. Place the equipment in a cool place where away from direct sunlight.
7. Store the equipment in a clean place. Make sure the temperature and humidity are appropriate and no condensation.
8. Storage SOC: 25%~50% SOC. Circle the charge-discharge every 3 months.
9. Recommended storage temperature: -20~45°C (less than one month) or 0°C~35°C (less than one year).
10. Recommended storage humidity: 0%~95%RH (no condensation). Do not install the battery if there is any moisture or condensation.

3.2 Installation Environmental Requirement

3.2.1 Cleanliness

The battery system has high voltage connectors. The environment condition will affect the

isolation performance of the system.

Before installation and system power on, the dust and iron scurf must be removed to keep a clean environment. And the environment must have certain anti-dust ability.

Dust and humidity condition shall be periodic checked during the system continuous operation.

3.2.2 Temperature

HBP system working temperature range: 0°C~50°C; Optimum temperature: 18°C~30°C;
Caution: Out of the working temperature range will cause the battery system over / low temperature alarm or protection which may lead to the cycle life reduction.

3.2.3 Cooling System

It is essential to equip a cooling system to keep the battery system in a relevant temperature range.

Caution: Out of the working temperature range will cause the battery system over / low temperature alarm or protection which may lead to the cycle life reduction.

3.2.4 Heating System

It is essential to equip a heating system to keep the battery system in a relevant temperature range. If the environment is lower than 0 °C ,the system may be shut down for protection purpose. It is necessary to open the heating system at first.

Caution: Out of the working temperature range will cause the battery system over / low temperature alarm or protection which may lead to the cycle life reduction.

3.2.5 Fire-extinguisher System

The room must be equipped with fire-extinguisher system for safety purpose. The fire system needs to be regularly checked to be in normal condition. Refer to the using and maintenance requirements, please follow local fire equipment guidance.

3.2.6 Grounding System

Make sure the grounding point for the battery system is stable and reliable before the battery installation. The resistance of the grounding system must be $\leq 100\text{m}\Omega$.

3.3 Installation clearance requirements

Please note that the battery should be installed with a minimum safe clearance from the surrounding equipment or battery. Please refer to the minimum clearance diagram below.

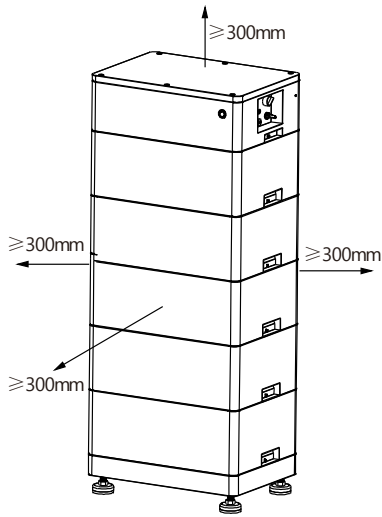

3.4 Installation location precautions

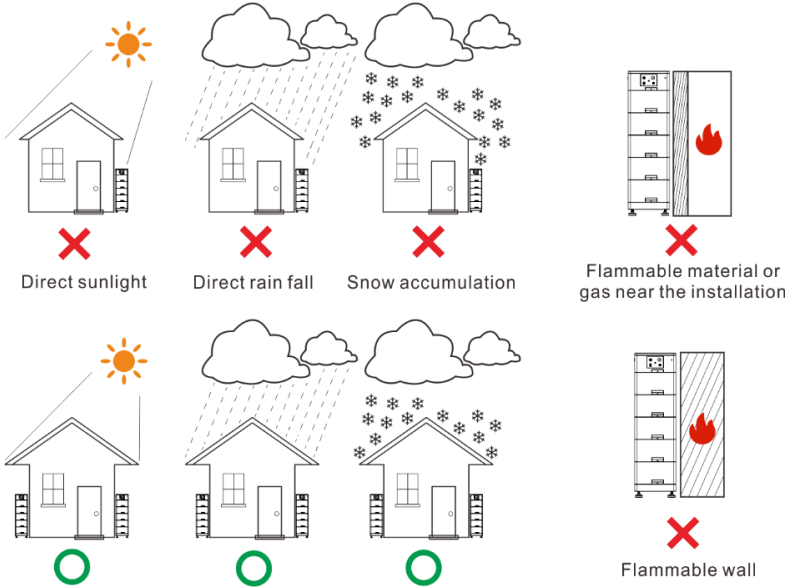

3.5 Installation Angle Requirements

Install the equipment vertically, no tilt or upside down.

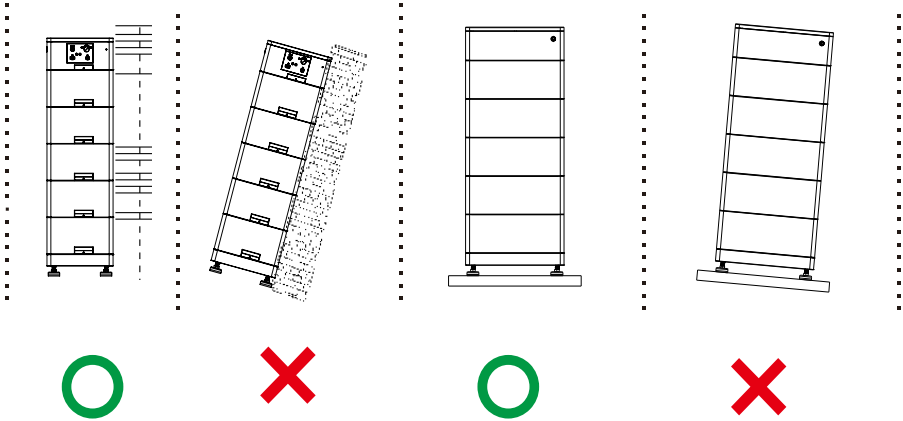

3.6 Safety Gear

It is recommended to wear the following safety gear when dealing with the battery pack.



Insulated gloves



Safety goggles









Safety shoes

3.7 Unpacking inspection

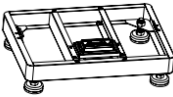
Check the following items before receiving the product.

1. Check the outer packing box for damage, such as holes, cracks, deformation, and other signs of equipment damage. Do not unpack the package and contact the supplier as soon as possible if any damage is found.

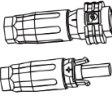
2. Check the product model. If the product model is not what you requested, do not unpack the product and contact the supplier.
3. Check the deliverables for correct model, complete contents, and intact appearance. Contact the supplier as soon as possible if any damage is found.

Item	Quantity	Figure
Battery Controller	1	
Base	1	
Battery	N	
Mounting Screws	N	
Mounting Bracket	1	
Mounting Accessories	1	
Battery Plugs (SUNCLIX)	1	
BMS Terminal	1	
Documents	1	

N = Quantity depends on the battery system.

3.8 Equipment installation

3.8.1 Installation Preparation

Operations such as transportation, turnover, installation, and so on must meet the requirements of the laws and regulations of the country or region where it is located.

1. Consider the weight of the equipment before moving it. Assign enough personnel to move the equipment to avoid personal injury.
2. Keep balance to avoid falling down when moving the equipment.
3. Confirm that the DC breaker is in the OFF state to ensure that there is no live operation.

3.8.2 Mechanical installation

3.8.2.1 Place the base

- Choose an appropriate place to set base. Place the base cling to the wall; the adjustable feet can adjust the base level.

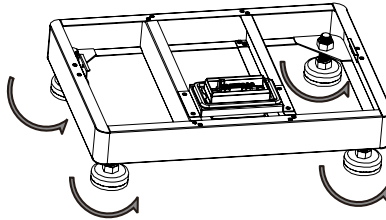

3.8.2.2 Battery module installation

- Install all the HBP10230 modules on the base from bottom to up, each module uses 2 screws to fix. Install the remaining batteries according to the actual battery system type.

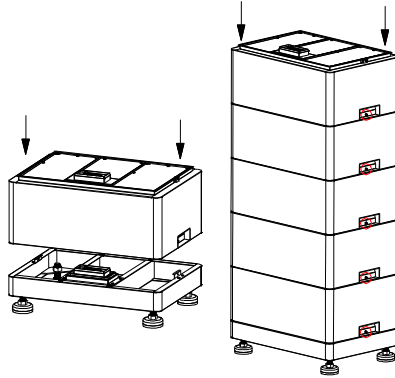

3.8.2.3 Battery Controller installation

- Put the Battery Controller above the Battery modules securely.
- Mark the drilling hole using a marker, then remove the Battery Controller.
- Drill holes using the hammer drill.
- Secure the brackets to prevent the Battery Controller from falling down.
- Battery Controller uses 2 screws to fix on the left and right sides.

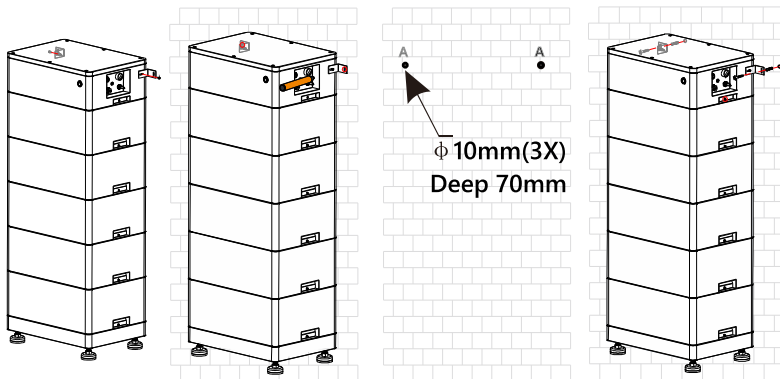

3.8.3 Electrical installation

Danger: The battery system is high voltage DC system. Must make sure the grounding surface of the Tower is stable and reliable.

3.8.3.1 Grounding

- Connect the PE cable first before installing the equipment. Disconnect the PE cable before dismantling the equipment. The PE terminal is equipped at the side of the Battery Controller. PE Conductor cross-section: 10mm²:

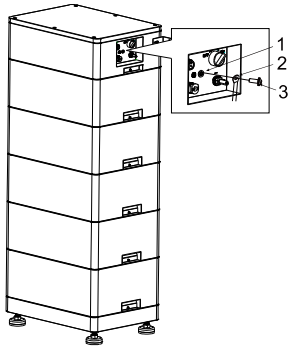

No	Model Name
1	Battery Controller
2	M6 terminal lug with protective conductor
3	M6x12 pan head screw
Tighten it firmly into the housing (T25 screwdriver, torque:	

3.8.4 Battery system self-test

3.8.4.1 Switch the Battery Controller “Circuit Breaker” to the "ON" state.

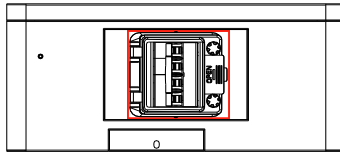

3.8.4.2 Switch on the “Power On Switch”.

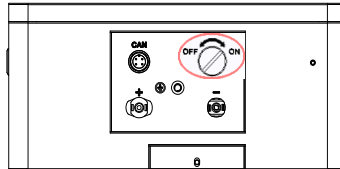

3.8.4.3 Press the “Button Indicator” for about 5S. The system start-up.



3.8.4.4 Use a multimeter to measure the output voltage on the positive and negative ports of the Battery Controller. The output voltage should conform to the voltage range in the table "Table 2-1 the parameter of HBP system". Otherwise, the system will be not working properly.

Danger: The voltage of the battery is too high, please pay attention to do self-protection during the measurement.

3.8.5 Shut down the system.

- Switch off the "Button Indicator"

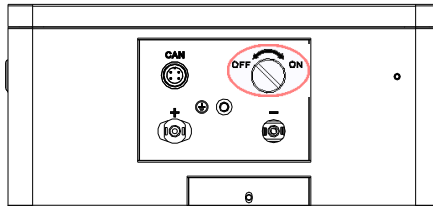

- Switch the Battery Controller "Circuit Breaker" to the "OFF" state .

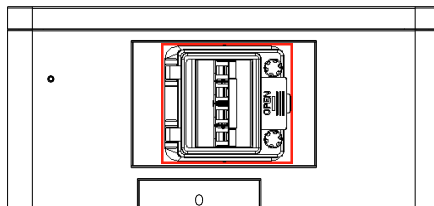

3.8.6 Connecting inverter

Caution: An external DC Breaker that operates both positive and negative conductors simultaneously between the Battery Controller and inverter on the power cable is recommended. After waking up the Battery Controller and ensure that the Battery Controller is pre-charged, you can turn on it.

Danger: Please confirm that the battery system is in the off state before connecting. It may cause electric shock to personnel and damage to the inverter if the battery is directly without power off.

- Connect the positive and negative connectors with the positive and negative power

cables together. Both ends must have connectors, and the connector on the inverter side is provided by the inverter.

Step 1
 Open the spring using a blade screwdriver

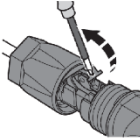

Step 2
 Insert the stripped wire with twisted wires.
 The wire ends have to be visible in the spring.
 Make sure the spring is closed firmly.

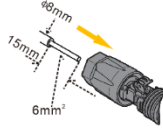

Step 3
 Use a suitable and calibrated torque wrench, size 15. Use an open-jaw wrench, size 16, to hold the connector in place.

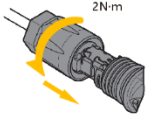

Step 4
 Remove the waterproof caps from battery terminals

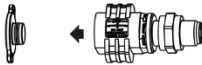

If there is an unused terminal, please seal it with the cap

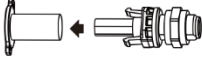

Step 5
 Insert the connectors into the terminal till you hear an audible click.

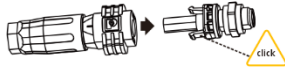
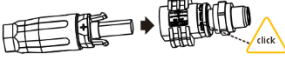
- Connect the BMS CAN communication cable to the inverter CAN port.

Step 1

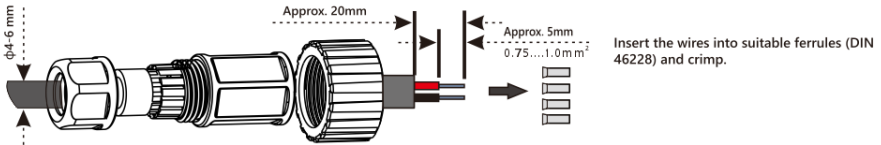

Step 2

Insert the crimped conductors accordingly into their corresponding terminals and tighten the screws.



Step 3

Assemble the locking cap, threaded sleeve and swivel nut together.

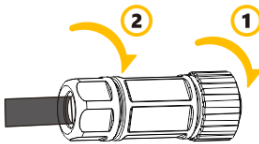

Step 4

Screw the connector into the corresponding socket and tighten firmly.

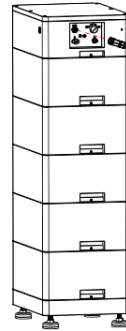

Warning:

Check all the PE cable, power cable, communication cable, and terminal resistor are connected correctly and securely.

- Switch on the inverter, to make sure all the power equipment can work normally.
- Start the battery system. Referring to the section“3.8.4”.

4. Maintenance

4.1 Trouble Shooting

Danger: The battery system is a high voltage DC system, operated by professional and authorized person only.

Before check the failure, must check all the cables connection. Switches are right or not (refer to section 3.7.4), and if the battery system can be woken up normally.

No	Problem	Possible Reason	Solution
1	The battery has no voltage output, and "POWER ON" Light is off.	The DC breaker of the Battery Controller didn't be turned on	Turn on the DC breaker of BDU
2		The "POWER ON" switch of the Battery Controller was not switched on	Switch on the "POWER ON" button
3		Battery is in sleep state.	Long press the "POWER WAKE" button for about 5S
4		Battery gets into over-discharged protection.	Charge the battery to relieve the protection state
6	The battery has no voltage output, but "POWER ON" are on.	The relay in Battery Controller is faulty	Replace a new Battery Controller.
7	When the battery is connected to the inverter, the DC breaker trips automatically	The circuit between the battery and the inverter has a short circuit point.	Check whether there is a short circuit in the circuit between the battery and the inverter; Check if the inverter is faulty.
8	Communication failure between battery and inverter	The wrong battery model type is selected on the inverter	Select correct battery model type on the inverter

4.2 Replacement of main component

Danger: The Tower battery system is a high-voltage DC system, that only can be operated by a professional and authorized person.

4.2.1 Replacement of Battery Controller

4.2.1.1 Turn off the whole battery system. Ensure the Negative terminal and Positive terminal have no power. The shutdown progress refers to section 3.7.5

4.2.1.2 Remove the screws on the Battery Controller and remove the Battery Controller from the system.

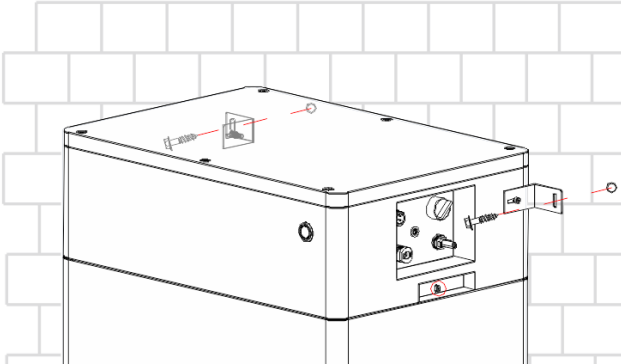

4.2.1.3 Change a new Battery Controller. Then fix the screws.

4.3 Battery Maintenance

Danger: The maintenance of battery only can be operated by professional and authorized person. You need turn off the battery system firstly when you do some maintenance things.

No	Maintaining Item	Maintaining Period
1	Check whether the locking brackets are secured, tighten it if not.	Once every 6 months
2	Check whether the outer enclosure is broken. Repair the painting or contact after-sales service if there is any broken.	Once every 6 months
3	Check whether there is an exposed cable. Replace the exposed cable or contact the after-sales service for help.	Once every 6 months
4	Check whether there is any dust around the battery module. Clean the dust if there is any to avoid affecting heat dissipation.	Once every 6 months
5	Check whether there is any liquid or pest near the battery to avoid intrusion in a long term.	Once every 6 months
6	Check the voltage of battery system through the monitor software. Check whether the system voltage is normal or not. For example, Check Single cell's voltage is out of rated range or not.	Once every 6 months
7	Check the SOC of battery system through the monitor software. Check the SOC of battery string is normal or not.	Once every 6 months
8	The battery system will become unbalanced if have not be charged fully for a long time. Solution: Preform the balancing maintenance (fully charged) every 3 month. Generally, this maintenance progress needs to be completed when external devices such as the monitor software and battery and inverter are in good communication.	Once every 6 months
9	Under low load condition (low current), control the output relay OFF and ON to hear the relay has click voice, that's mean this relay can off and on normally.	Once every 6 months

5. Transportation

Battery module will pre-charged to 50% SOC or according to customer requirement before shipment. The remaining capacity of battery cell is determined by the storage time and condition after shipment.

- The battery modules meet the UN38.3 certificate standard.
- In particular, special rules for the carriage of goods on the road and the current dangerous goods law, specifically ADR(European Convention on the International Carriage of Dangerous Goods by Road), as amended, must be observed.

6. Disclaimer

The battery protects this product under warranty when it is installed and used as listed in this manual. Violation of the installation procedure or use of the product in any way not described in this manual will immediately void all warranties on the product.

The battery does not provide warranty coverage or assume any liability for direct or indirect damages or defects that result from the following causes:

- Force majeure (flooding, lightning strike, overvoltage, fire, thunderstorm, flooding etc.)
- Improper or noncompliant use
- Improper installation, commissioning, start up or operation (contrary to the guidance detailed in the installation manual supplied with each product)
- Inadequate ventilation and circulation resulting in minimized cooling and natural air flow
- Installation in a corrosive environment
- Damage during transportation
- Unauthorized repair attempts
- Failure to adequately maintain the equipment. An on-site inspection by a qualified technician is possible following 120 months of continuous use. Warranty claims made beyond 120 months from date of commissioning may be declined if it cannot be demonstrated that the equipment has been adequately maintained
- External influence including unusual physical or electrical stress (power failure surges, inrush current, etc.)
- Use of an incompatible inverter or devices
- Connect to other brands inverters without authority from the battery

HYPONTECH

 **HYPON.COM**
@ HYPONTECH SOLAR ENERGIZING FUTURE

SUZHOU HYPONTECH Co., LTD. - HQ OFFICES

SUZHOU HEFENG SCIENCE AND TECHNOLOGY
INNOVATION PARK

No.2, TAISHAN ROAD, SUZHOU CHINA · 215129

T +86 512 807 12199

E INFO@HYPON.COM

W WWW.HYPON.COM

SUZHOU HYPONTECH Co., LTD. -MANUFACTURING

No.588 WUTAISHAN ROAD, SND, SUZHOU 215000,
CHINA

HYPONTECH DEUTSCHLAND GmbH – GERMANY BRANCH

RUDOLF DIESEL STR. 11, 69115 HEIDELBERG

W SERVICE.EU@HYPONTECH.COM

BRAZIL OFFICE - SÃO PAULO

JOSÉ ROCHA BOMFIM AVENUE, 214 BLOC B

LONDRES, ROOM 217, CAMPINAS, SÃO PAULO

- CEP 13080-650

W SERVICE@HYPONTECH.COM